

# MANUAL TH-172

Universal hardness tester



*Changes in products and/or product specifications can emerge due to new technologies and continuous development.*

*We reserve the right to change or modify specifications of products without prior notice.*

*We recommend you to contact our sales office for up-to-date information.*

*© All rights reserved*

---

## **CONTENTS**

<b>1</b>	<b>INTRODUCTION</b>	<b>2</b>
1.1	Features	2
1.2	Main application and testing range	2
1.3	Specification	3
1.4	Working condition	3
<b>2</b>	<b>STRUCTURE FEATURE &amp; TESTING PRINCIPLE</b>	<b>4</b>
2.1	Structure feature	4
2.2	Working principle	5
<b>3</b>	<b>SPECIFICATIONS</b>	<b>6</b>
<b>4</b>	<b>OPERATION</b>	<b>7</b>
4.1	Preparation before operation	7
4.2	Measurement	8
<b>5.</b>	<b>SPECIAL PROMPT</b>	<b>10</b>
<b>6.</b>	<b>OPERATION EXPLAIN IN DETAILS</b>	<b>11</b>
6.1	Switch on	11
6.2	Measuring operation	12
6.3	Key-press operation	12
6.4	Switch off	12
6.5	Menu structure	13
6.6	Common functions	14
6.7	Memory manager	15
6.8	Test setting	17
6.9	System setting	20
6.10	Calibration	21
6.11	Battery replacement	21
6.12	Backlight	22
6.13	Auto Power Off	22
<b>7</b>	<b>MAINTENANCE AND REPAIR</b>	<b>23</b>
7.1.	Maintenance	23
7.2	Repair	23
<b>8</b>	<b>INSPECTION PERIODS</b>	<b>24</b>
<b>9</b>	<b>NOTICE FOR USES</b>	<b>24</b>
<b>10</b>	<b>NOTICE OF TRANSPORTATION AND STORAGE</b>	<b>24</b>
	<b>EC-DECLARATION OF CONFORMITY</b>	<b>25</b>

# **1 INTRODUCTION**

## **1.1 FEATURES**

- LCD display 128×32 dot matrix
- USB communication interface
- Impact direction automatically identifying
- Memory 270 average data in 9 files
- Upper and lower limit pre-setting
- Battery capacity display and power off automatically lack of voltage
- Backlight for convenient use in darkness
- Software calibration
- AAA 1.5V (7#) battery 2 pc
- Computer software available

## **1.2 MAIN APPLICATION AND TESTING RANGE**

### **1.2.1 Main application**

- The installed machinery and permanently assembled parts
- Die cavity of moulds
- Heavy and large workpiece
- Failure analysis of pressure vessel, steam turbo set and other equipment
- Narrow space workpiece
- Axletree and other spare parts
- Material identification of the metal material warehouse
- Quick inspection for large workpiece
- Others.

## 1.2.2 Testing range

See table 1.  
Table 1

Material	Hardness scale	Application range
Steel and Cast Steel	HRC	20.0~69.5
	HB	80~683
	HV	80~996
	HS	31.8~102.1
Cold Work Tool Steel	HRC	20.7~68.2
	HV	100~941
Cast Aluminum Alloys	HB	23~210
	HRB	23.7~85

## 1.3 SPECIFICATION

- TH-172 Main Unit 1
- AAA 1.5V (7#) battery 2
- Small supporting ring 1
- Cleaning brush 1
- Hardness test block 1
- USB communication cable 1
- Driver disk for computer 1

## 1.4 WORKING CONDITION

- Working temperature: 0°C~40°C
- Humidity: ≤90%
- The surrounding environment should be no vibration, no strong magnetic field, corrosive medium and heavy dust.

## 2 STRUCTURE FEATURE & TESTING PRINCIPLE

### 2.1 STRUCTURE FEATURE

Structure feature see figure 1.

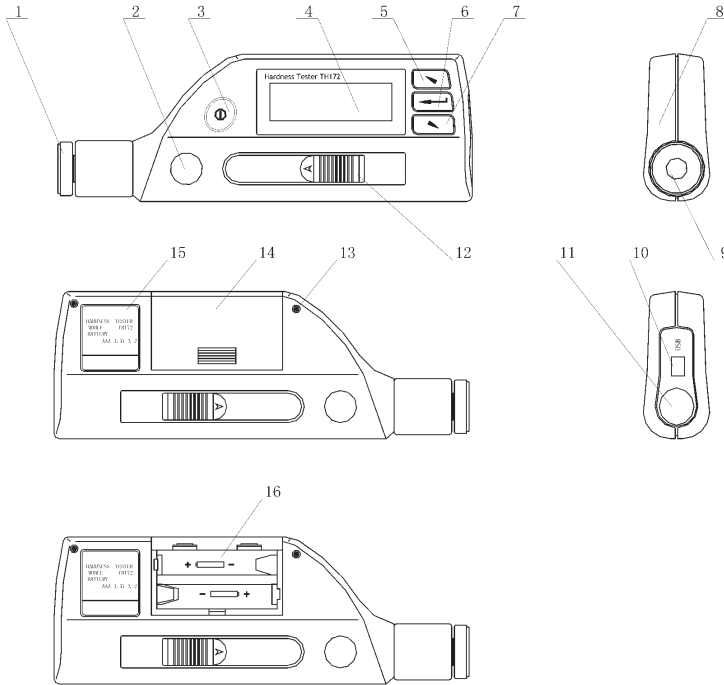

Figure 1

- |   |                 |    |                  |
|---|-----------------|----|------------------|
| 1 | supporting ring | 9  | impact device    |
| 2 | concave hole    | 10 | USB interface    |
| 3 | switch key      | 11 | release key      |
| 4 | display window  | 12 | loading key      |
| 5 | operation key   | 13 | bolt             |
| 6 | confirm key     | 14 | battery cover    |
| 7 | operation key   | 15 | nameplate        |
| 8 | shell           | 16 | battery location |

## 2.2 WORKING PRINCIPLE

The basic principle is: The impact object of certain weight pounds at the testing surface under certain test force. Measure the impacting velocity and the rebounding velocity of the impact object respectively when it is 1mm above the testing surface.

The calculation formula is:

$$HL=1000 \times VB / VA$$

Where:

*HL*- Leeb hardness value

*VB*- Rebounding velocity of the impact object

*VA* - Impacting velocity of the impact object

### 3 SPECIFICATIONS

- Hardness Scales: HLC/HB/HRC/HV/HS/HRB
- Impact device C
- Measuring range 230~960HLC
- Measuring direction +45°, +90°, 0°, auto identification;
- Display 128×32 dot matrix LCD with backlight
- Data memory 270 average data in 9 files
- Power AAA 7# 1.5V 2pc
- Continuous working time ca. 150 Hours  
(without backlight);
- PC / Interface USB
- Dimensions: 160mm×60mm×25mm
- Weight: about 180g.



## **4 OPERATION**

### **4.1 PREPARATION BEFORE OPERATION**

#### **4.1.1 Preparation for sample surface**

In order to reduce the effect of surface roughness of the testing object on the measuring result, it is necessary to make the surface to be tested smooth enough, with the Ra value not exceeding 0.4 $\mu$ m, and clean the surface and ensure that it is free of oil.

#### **Measuring on internal and external cylindrical surface and spherical surface**

In testing a circular curved surface, the large support ring should be used when the curvature radius is bigger than 60mm and small support ring should be used when the curvature radius is bigger than 30mm and shaped support rings should be used when the curvature ranges from 11mm to 30mm. The shaped supporting rings may be ordered separately from our company.

- No support is needed for testing objects weighing over 1.5kg.
- When a testing object is 0.5-1.5kg and the testing part is suspended, it should be supported by an object weighing more than 1.5kg in order to prevent the testing piece from being bend, deformed or moved.
- When a testing object is less than 0.5kg, it should be coupled with a support object weightier than 1.5kg. The coupling surface of the testing object and the support surface must be even and smooth, with no surplus coupling agent seen. The testing direction must be perpendicular to the coupling surface.
- The testing object should be no less than 0.05kg and the minimum thickness should not be less than 1mm. The hardened surface should not be less than 0.2mm in thickness.
- The clipped surface should be perpendicular to the testing direction.
- When the testing object is a large plate, rod or curve surfaced work piece, it is easy to cause it to deform or out of balance even if it is fairly big in weight and thickness, thus leading to inaccurate measurement. So it should be reinforced or supported on the back of the testing point.
- The testing object should be free from magnetism.

#### **4.1.2 Preset test parameters**

Refer to Item 6.8.

## 4.2 MEASUREMENT

The instrument can be checked with standard test block, the accuracy and repeatability displayed should be within  $\pm 12\text{HLC}$ .

### 4.2.1 Loading

Press the gauge vertically onto the surface of workpiece, hold the unit by left hand, hold the loading rubber key and pull down it to finish the loading

### 4.2.2 Measuring

- Press the release button on top of the unit to do the measurement. The sample and the main unit as well as the operator are all required being stable
- Usually, test 5 times on the workpiece. The data dispersion should not be more than  $\pm 15\text{HL}$  from the average value
- The distance between any two indentations or from the center of any indentation to the edge of tested sample should conform to the regulation of table 6

*Table 6*

Distance between any two indentations mm	Indentation to the edge of tested sample mm
> 2mm	> 4mm

- For special material, if accurate conversion from the Leeb hardness into other hardness method is wanted, contrastive test must be done to get conversion relations. Use inspected qualified Leeb hardness tester and corresponding other hardness tester to test at same sample respectively. For each hardness value, measure 5 Leeb hardness values. using Leeb hardness arithmetic average value and corresponding hardness method average value as correlative value to make individual hardness contrastive curve see figure 3.

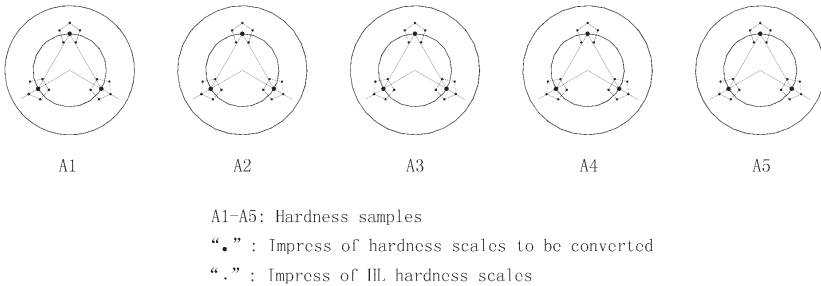

Figure 3

### 4.2.3 Testing result

- In front of Leeb hardness symbol HL, expresses the hardness value; behind HL expresses type of impact device.

For example:

700HLC expresses using C type of impact device measured Leeb hardness value is 700

- For other hardness scale converted from Leeb hardness scale, put the symbol of corresponding hardness scale in front of Leeb hardness scale.

For example:

400HVHLC expresses using C type of impact device measured Leeb hardness value converted Vickers hardness value is 400.

## 5. SPECIAL PROMPT

- In normal condition, it could not memory present testing value while not reaching impact times which has been set. If want to memory, press **Cal. Average** at the main display interface to end the testing in advance and then memory
- When using the function of **Cal. Average** to end the testing in advance, the function of **Auto Save, Auto Trans.** etc. will not work
- Not all hardness methods can be converted to each other for all materials See table 1. The setting of hardness scale will recover to HL automatically after material setting is changed. So select **Material** first then select **Hardness Scale** when setting measure condition.

## 6. OPERATION EXPLAIN IN DETAILS

### 6.1 SWITCH ON

Press  to switch on the screen will show as follows in 2 seconds:



Then it enters the main display interface see figure 4.

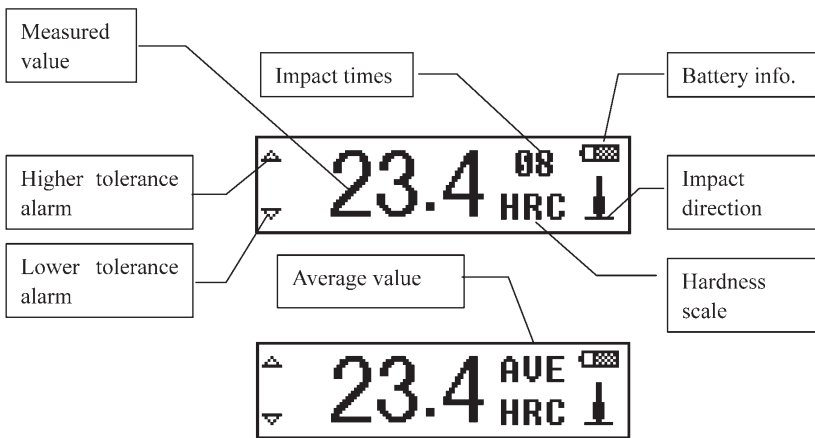

Figure 4



**Instruction of the main display interface:**

- **Measured value:**  
Display present single time measured value (without average value indicator), or display the present average value (with average value indicator).  
Display ↑ means over conversion or measured range, ↓ means lower than conversion or measured range.
- **Impact times :**  
Display the times that have been impacted, the according times will be displayed in reverse video when browsing single measured value.
- **Average value indicator :**  
After reaching the preset impact times, It appears to show the mean value.
- **Hardness scale:**  
Show the present hardness scale that has been selected.
- **Impact direction:**  
Show the present impact direction that has been selected.
- **Battery info:**  
Show the rest capacity of battery.
- **Over tolerance alarm :**  
It will display as ▲ when the present measured value or average value is within the tolerance range otherwise it will display as ▲.
- **Lower tolerance alarm:**  
It will display as ▼ when the present measured single value or average value is within the tolerance range otherwise it will display as ▼.

## 6.2 MEASURING OPERATION

The screen will display each measured value during each measurement under the measuring display interface, and the impact times add 1 accordingly if the measured value is beyond tolerance range the according mark will change to solid mark the average value will be displayed in 2 seconds when reaching the impact times.

## 6.3 KEY-PRESS OPERATION

- Press  or  to browse single measured value the impact times will be displayed in reverse video
- Press to  enter the menu.

## 6.4 SWITCH OFF

Press  to switch off.

## 6.5 MENU STRUCTURE

Preset tester parameters and the additional functions can be performed by the menu operation. At the main display interface, press to enter the main menu.

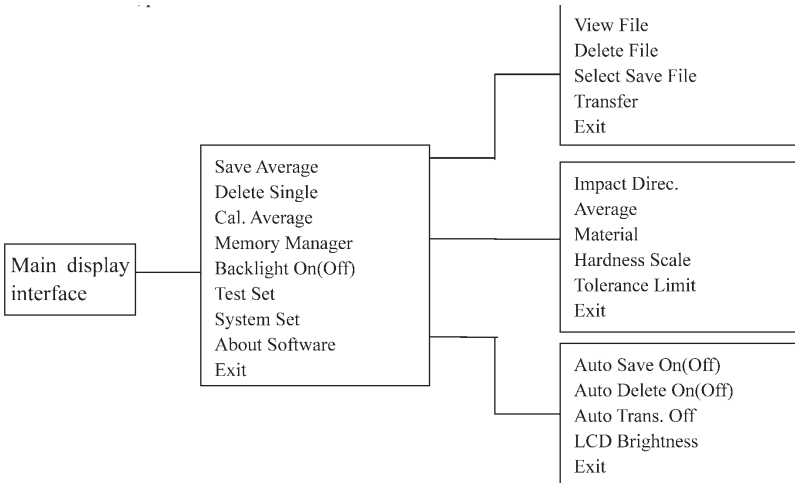



- For convenient operation, the common function such as "Save Average" "Delete Single" "Cal. Average" "Backlight On (Off)" have been put into main display interface
- The main display interface have the key **Exit** it is convenient to return to measuring interface
- By pressing **Exit** key the gauge will return to the measuring interface directly but not the previous menu.
- By pressing the key or users can choose all functions and sub-menu circularly.



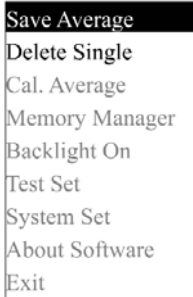

## 6.6 COMMON FUNCTIONS

Press  to enter the main menu under measuring interface.



Press  or  to move the cursor to demanded function and press to  confirm.

*Note:*  
Press  or  to see pale letter.

- **Save Average:**  
Memory the present average value.  
*Note:*  
*The memory can not be processed under the both position of not reaching preset impact times and not choosing "Cal. Average".*
- **Delete Single:**  
Delete the last measured value Delete the certain measured value when browsing the single measured value Delete the last single measured value when displaying average value.  
*Note:*  
*Please move the cursor to "YES" or "NO" and press  to confirm when delete.*
- **Cal. Average:**  
Display the average measured value when impact times have not reached preset times.
- **Backlight On (Off):**  
"Backlight On" will be displayed when choosing the backlight  
"Backlight Off" will be displayed when not choosing the backlight.  
*Note:*  
*Press any one of the keys , ,  when switch on the backlight will be chose.*



## 6.7 MEMORY MANAGER

The instrument includes 9 files and each one can memory 30 measured average value.

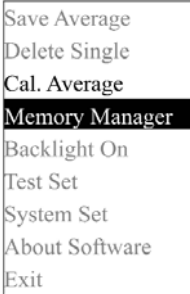

You can choose another file to memory when 30 measured average value is stored.  
Press to enter the main menu when on measuring display interface.

Press , to move the cursor to **Memory Manager** press enter **Memory Manager** .

*Note:*  
The pale letter can be seen by pressing or .



Press , to move the cursor to certain function key and press .

*Note:*  
The pale letter can be seen by pressing , .

### 6.7.1 Browsing file

Firstly please choose the file number to be browsed.

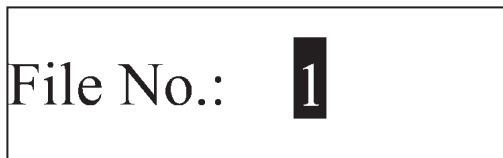



Press , to choose the file number.  
Press to confirm.

No.01	789HL
No.02	517HL
No.03	788HL
No.04	522HL

Press , to turn the page.  
Press return to Memory Manager .



### 6.7.2 Delete file

Firstly please choose the file number to be deleted.  
Press ,  to choose the file number.



Press  enter confirm delete interface.





Press ,  to choose.  
Press  to confirm and return to Memory Manager .

### 6.7.3 Memory file choosing

Choose the file number for memory.



Press ,  to choose the file number.  
Press  to confirm and return to measuring display interface.

## 6.8 TEST SETTING

Press to enter the main menu under measuring display interface.

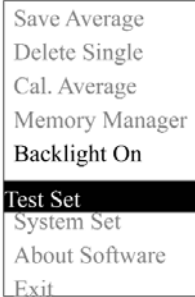

Press , to move the cursor to **Test Set** and press .

*Note:*  
The pale letter can be seen by pressing , .



Press , to move the cursor to certain function and press.

*Note:*  
The pale letter can be seen by pressing , .

### 6.8.1 Selection of impact direction

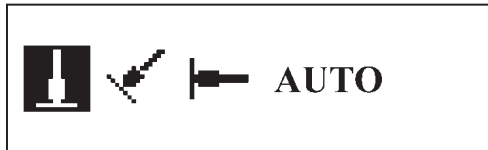

Press , to move the cursor to select the impact direction.  
Press to finish the setting and return to measuring display interface.  
If preset impact direction to **AUTO** the instrument can identify the impact direction and correct the wrong direction automatically.

### 6.8.2 Mean times setting 1

The mean times can be modified from 1 to 10.



Mean Times: 10

Press ,  to modify.

Press  to finish set and return to measuring display interface.

### 6.8.3 Material setting





(Cast) Steel  
CWT. Steel  
Cast Alumin

Press ,  to move the cursor to certain material to be set.

Press  to finish set and return to measuring display interface.

Note:

1. The hardness scale will come back to HL after material setting.
2. Choose material firstly before choosing hardness scale.
3. The pale letter can be seen by pressing ,  .

### 6.8.4 Hardness scale setting



Press , to move the cursor to certain scale to be set.  
Press to finish and return to measuring display interface.

Note:

1. The hardness scales that displayed here only are corresponding to the choose material.
2. Choose material firstly before choosing hardness scale.
3. The hardness scale will come back to HL automatically after material setting.

### 6.8.5 Upper and lower limit setting



Press , to move the cursor to the position of figure.  
Press to move the cursor to next figure the cursor will come back to measuring display interface when moving to the last figure.

Note:

1. The instrument will remind you to reset the upper and lower limit when presetting is out of range.
2. The lower and upper limit will reverse automatically when the lower setting is over the upper setting.

## 6.9 SYSTEM SETTING

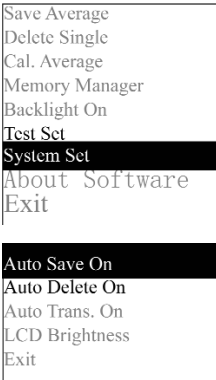

Press to enter the main menu under measuring display interface.

Press , to move the cursor to **System Set** and press .

*Note:*  
The pale letter can be seen by pressing , .

Press , to move the cursor to certain function to be set  
Press to finish or enter into corresponding interface.

- **Auto Save:**  
It stores the average value automatically after measuring and displaying average value. The "Auto Save On" displays when the function is turned off, and the "Auto Save Off" displays when the function is turned on.
- **Auto Delete:**  
The "Auto Delete On" displays when the delete function is turned off and the "Auto Delete Off" displays when the function is turned on.
- **Auto Trans.:**  
The current group value can be transmitted out via USB port. For computer see 6.15. The "Auto Trans On" displays when the auto transmitting function is turned off, and the "Auto Trans Off" displays when the auto transmitting function is turned on.



### 6.9.1 LCD brightness setting



Press to add the brightness.  
Press to reduce the brightness.  
Press to finish and return to measuring display interface

*Note:*  
1 Bright means more brightness.  
2 Dark means less brightness.

## 6.10 CALIBRATION



The tester should be calibrated using standard test block before use this gauge for the first time, or reuse after a long time. Press ,  and press  simultaneously the gauge will be switched on and enter the calibration state.

Calibration  
0/5 Times

Preset the impact direction as .  
Measure 5 points on the standard hardness block.

Average= 550  
Nominal= 550





It will display average value after measurement.

Press ,  to input the standard value of test block.  
Press  to finish calibration.  
Range of adjustment:  $\pm 15\text{HL}$ .

## 6.11 BATTERY REPLACEMENT

- When battery capability run out, the battery display symbol will glint as  please replace battery as soon as possible.
- When replacing the battery the tester should be switch off firstly.
- Push out the battery cover, install 2 AAA 7# 1.5V battery into the battery compartment according to correct direction.
- Push in the cover after installation of battery.
- The replacement of battery should be finished within 15 minutes, if beyond it the memory data may lost.
- Please collect the used battery avoiding pollution.

## 6.12 BACKLIGHT

The LCD screen has EL backlight. It is convenient to use in dark condition. Press any one of three keys , ,  and press  simultaneously, the backlight will be function on. Also the backlight can be set under the main menu see 6.6.

## 6.13 AUTO POWER OFF

- The tester has the function of auto power off to save the power of battery.
- If there is neither measurement nor any operation within 5 minutes, the tester will shut off automatically. The screen will glint for 20 seconds before power off. Except  key, press any key to stop the twinkle of LCD screen and stop the operation of power off at the moment.
- While voltage of battery is too low, the tester will show < Battery Empty!>, then power off automatically.



## **7 MAINTENANCE AND REPAIR**

### **7.1. MAINTENANCE**

- After the impact device is used for 1000–2000 times, use the cleaning brush provided to clean the guide tube and the impact body. To clean the guide tube, unscrew the support ring firstly, then take out the impact body, spin the cleaning brush in counter-clock direction into th bottom of guide tube and take it out for 5 times, and then install the impact body and support ring again.
- Release the impact body after use.
- Any lubricant is absolutely prohibited inside the impact device.

### **7.2 REPAIR**

- When using standard Rockwell hardness block to test, if all the error is bigger than 2 HRC, maybe the test tip is invalid because of abrasion. Changing the test tip or impact object should be considered.
- When the hardness tester appears any other abnormal phenomena, please do not dismantle or adjust any fixedly assembled parts by yourself. You can contact with your service department.

## **8 INSPECTION PERIODS**

The inspection period of such hardness tester should not beyond one year. Uses should arrange the inspection according to its own condition.

## **9 NOTICE FOR USES**

Non-guaranty parts:

- 1 Outside frame
- 2 Battery cover
- 3 Display window
- 4 Impact body
- 5 Support rings

## **10 NOTICE OF TRANSPORTATION AND STORAGE**

- Please keep it away from vibration, strong magnetic field, corrosive medium, dampness and dust.

## EC-DECLARATION OF CONFORMITY

This certifies that the following designated product  
**TH-172 (Portable hardness tester)**  
complies with the essential protection requirements of  
Council Directive 89/336/EWG approximation of the laws of the  
Member States relating to electromagnetic compatibility.

This declaration applies to all specimens manufactured  
in accordance with the manufacturing drawings  
which form part of this declaration.

Assessment of compliance of the product with the requirements relating  
to the compatibility was based on the following standards:  
EN55022, EN60555-2, EN60555-3, EN50082-1

This declaration is the responsibility of the manufacturer/importer:

Company name: INNOVATEST Europe BV  
Address: Borgharenweg 140  
Telephone / Telefax: +31-43-3520060 / +31-43-3631168  
Name of the subscriber: Nicole Paulissen-Schiffer  
Position: General Manager

Maastricht



**City**

**Authorised representative signature**

**CORPORATE HEAD OFFICE**  
**MANUFACTURING, DISTRIBUTION & SERVICE**

**INNOVATEST Europe BV**

Borgharenweg 140

6222 AA Maastricht (The Netherlands)

Phone: +31 43 3520060

Fax: +31 43 3631168

Email: [info@innovatest-europe.com](mailto:info@innovatest-europe.com)

[www.innovatest-europe.com](http://www.innovatest-europe.com)

IN09-146