

# Surface Roughness Tester SRTPro



## Instruction manual



## CONTENT

<b>1</b>	<b>ROUGHNESS TESTER OVERVIEW</b> .....	<b>3</b>
1.1	FEATURES OF INSTRUMENT .....	3
1.2	MEASUREMENT PRINCIPLE.....	3
<b>1.3</b>	<b>NAME OF EACH PART</b> .....	<b>4</b>
1.4	BUTTONS DEFINE .....	6
1.5	BATTERY CHARGING.....	6
1.6	CONNECTION METHOD OF SENSOR AND MAIN UNIT .....	7
<b>2</b>	<b>MEASURING OPERATION</b> .....	<b>9</b>
2.1	PREPARATION FOR MEASUREMENT.....	9
2.2	TURNING ON/OFF .....	9
2.3	STYLUS POSITION .....	10
2.4	START MEASUREMENT.....	10
2.5	MEASUREMENT RESULT DISPLAY .....	11
2.6	PRINT MEASUREMENT RESULTS.....	11
2.7	STORAGE MEASUREMENT RESULTS.....	12
2.8	MEASURING PARAMETER SETTINGS.....	12
2.9	STORAGE MANAGEMENT .....	13
2.10	DATE SETTINGS.....	15
2.11	SOFTWARE INFORMATION.....	15
2.12	PARAMETER CALIBRATION.....	16
2.13	PRINT SETUP .....	17
<b>3</b>	<b>OPTIONS AND USAGE</b> .....	<b>18</b>
3.1	ADJUSTABLE SUPPORT.....	18
3.2	MEASUREMENT STAND .....	19
3.3	EXTENDING ROD .....	19
3.4	STANDARD SENSOR.....	19
3.5	CURVED SURFACE SENSOR .....	20
<b>4</b>	<b>TECHNICAL PARAMETER AND FEATURES</b> .....	<b>22</b>
4.1	TECHNICAL PARAMETER.....	22
4.2	MEASURING RANGE .....	23
<b>5</b>	<b>GENERAL MAINTENANCE</b> .....	<b>23</b>
5.1	SENSOR .....	23
5.2	MAIN UNIT .....	23
5.3	BATTERY.....	23
5.4	STANDARD SAMPLE PLATE .....	24

<b>5.5</b>	<b>TROUBLESHOOTING</b> .....	<b>24</b>
<b>6</b>	<b>REFERENCES</b> .....	<b>24</b>
<b>6.1</b>	<b>TERMS</b> .....	<b>24</b>
<b>6.1.1</b>	<i>Terms</i> .....	<b>25</b>
<b>6.1.2</b>	<i>Traversing Length</i> .....	<b>25</b>
<b>6.2</b>	<b>PARAMETERS DEFINITIONS</b> .....	<b>26</b>
<b>6.3</b>	<b>RECOMMENDED TABLE OF THE SAMPLING LENGTH</b> .....	<b>28</b>

# 1 Roughness tester overview

The surfaces roughness tester is suitable for shop floor use and mobile measure to need of a small handheld instrument, its operation simple, function overall, measure fast, accuracy stability, take convenience. This tester applies to production site and can be used to measure surface roughness of various machinery-processed parts. This tester is capable of evaluating surface textures with a variety of parameters according to various national standards and international standard. The measurement results are displayed digital/graphically on the OLED and can be outputted to the printer.

## 1.1 Features

- ◆ Electromechanical integration design, small size, light weight, easy to operation;
- ◆ DSP chip control and data processing, high speed, low power consumption;
- ◆ Large measurement range;
- ◆ 14 parameters: Ra, Rq, Rz, Rt, Rp, Rv, R3z, R3y, RzJIS, Rs, Rsk, Rku, Rsm, Rmr
- ◆ 128 × 64 OLED dot matrix display, digital or graphic highlight display; no viewing angle;
- ◆ Display full information, intuitive and graphical displays all parameters;
- ◆ Compatible with ISO, DIN, ANSI, JIS multiple national standards;
- ◆ Built-in lithium-ion rechargeable battery and control circuit, high capacity, no memory effect;
- ◆ There are remaining charge indicator, charging hint;
- ◆ Tester has charging instructions, the operator can readily understand the level of charge
- ◆ Can work more than 20 hours while the power is enough;
- ◆ Large capacity data storage, can store 100 item of raw data and waveforms;
- ◆ Real-time clock setting and display for easy data recording and storage;
- ◆ With automatic sleep, automatic shutdown power-saving features;
- ◆ Reliable circuit and software design of prevent the motor stuck;
- ◆ Instrument can display a variety of information tips and instructions. For example Measurement result display, the menu prompts and error messages;
- ◆ Metal case design, rugged, compact, portable, high reliability;
- ◆ Can connected to the computer and printer;
- ◆ All parameters can be printed or print any of the parameters which set by the user;
- ◆ Optional curved surface pickup sensor, holes sensors, measurement stand, Sheath of sensor, extension rod, printer and analysis software;

## 1.2 Measurement principle

When measuring roughness of part surface, the pickup is placed on the surface of the part and then tracing the surface at constant rate. The pickup acquires the surface roughness by the sharp stylus in pickup. The roughness causes displacement of pickup which results in change of inductive value of induction coils thus generate analogue signal which is in proportion to surface roughness at output end of phase-sensitive rectifier. This signal enters data collection system after amplification and level conversion. After that, those collected data are processed with digital filtering and parameter calculation by DSP chip and the measuring result can be read on OLED, printed through printer and communicated with PC.

### 1.3 Name of each part

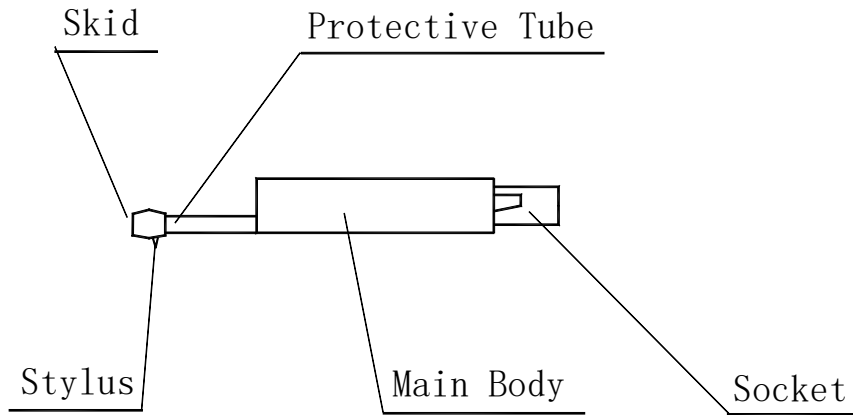

Sensor

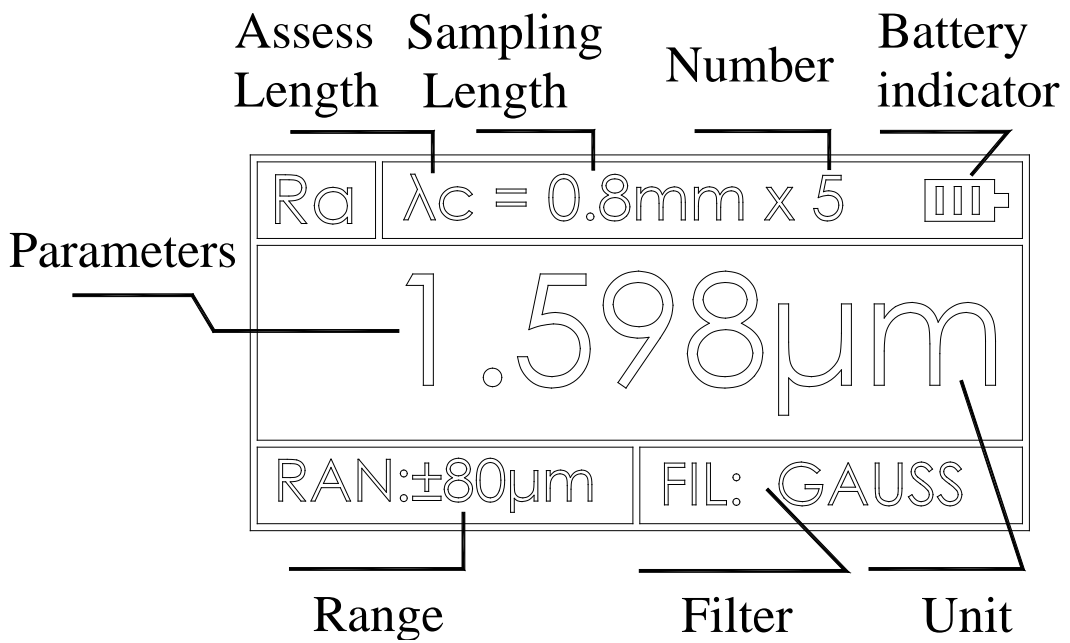

Display Interface

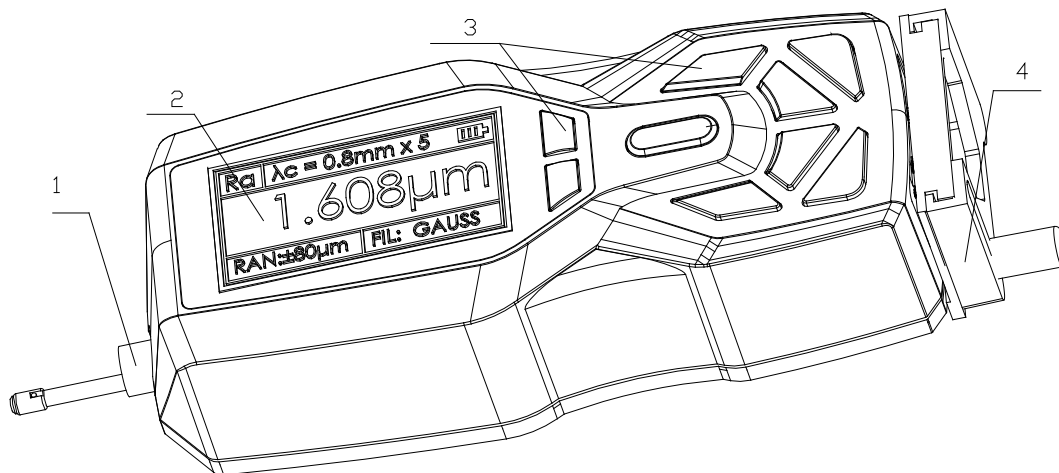

1. sensor 2. display 3. key area 4. adjustable support

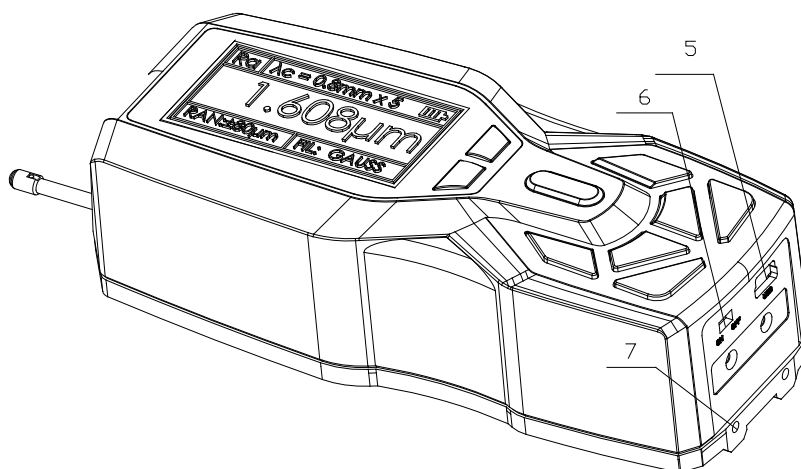









5. USB charge 6. power switch 7. fixing hole



Power switch is a total power switch on the instrument.

Turned off when not in use for a long time.

## 1.4 Buttons define

-  Power key: Press and hold min. 2 seconds to switch on or off
-  Stylus position keys: For switching between stylus position display
-  Start key: Start the measurement
-  Parameter selection Key: Used to view various parameters
-  Record storage key/ print key: For storing and print the record results
-  Up Arrow key: To select items for the switch
-  Down arrow keys: Select the item for switching
-  Menu / Enter key: To enter the menu settings
-  Cancel / Exit key: Used to exit the menu and unset

## 1.5 Battery Charging

When battery voltage is too low (battery voltage symbol  displays on the screen), the device should be charged as soon as possible. Use USB port of the instrument for charging. You can use the power adapter for charging or the computer's USB port for charging. Please notice that by using of the other power adapter, the output voltage should be 5V DC, the current should be greater than 800mA.

During charging the instrument displays animation and stops after the battery is full. Charging time is about 2.5 hours.

This instrument adopts lithium ion chargeable battery without memory effect and charging can be fulfilled at any time without affecting normal operation of the instrument.



When charging, ensure that the instrument side of the power switch is in the ON position



## 1.6 Connection of sensor and main unit

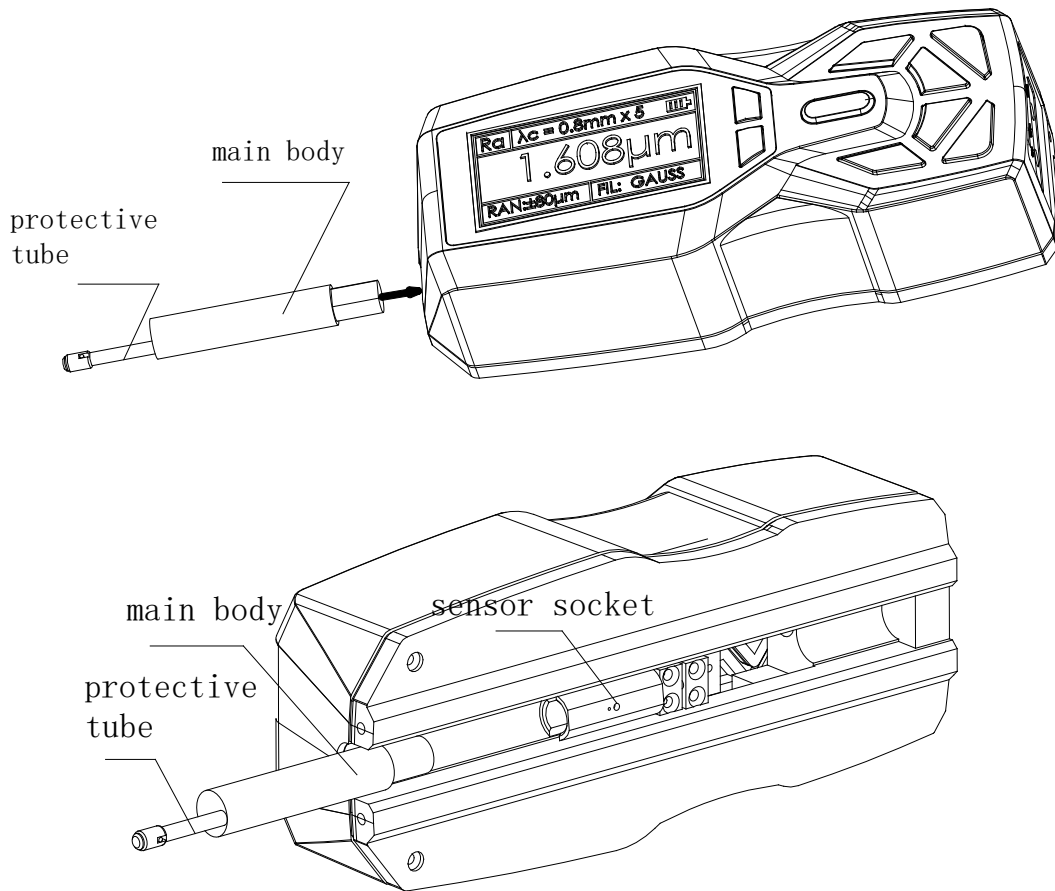

### Installation and Removing of sensor

For installation, hold the main body of sensor with hand, push it into connection adapter at the bottom of the instrument as shown in Figure and then slightly pushed it to the end of the sheath. To remove, hold the main body of pickup or the root of protective sheath with hand and slowly pull it out.



- 1、 Stylus of pickup is key part of this tester and great attention. should be paid to it.
- 2、 During installation and unloading, the stylus should not be touched in order. to avoid damage and affecting measurement.
- 3、 Connection of sensor should be reliable during installation.



## 2 Measuring Operation

### 2.1 Preparation for Measurement

Switch-on to check if battery voltage is normal;

Clear the surface of part to be measured;

Place the instrument correctly, stably and reliably on the surface to be measured;

Trace of the pickup must be vertical to the direction of process line of the measured surface.

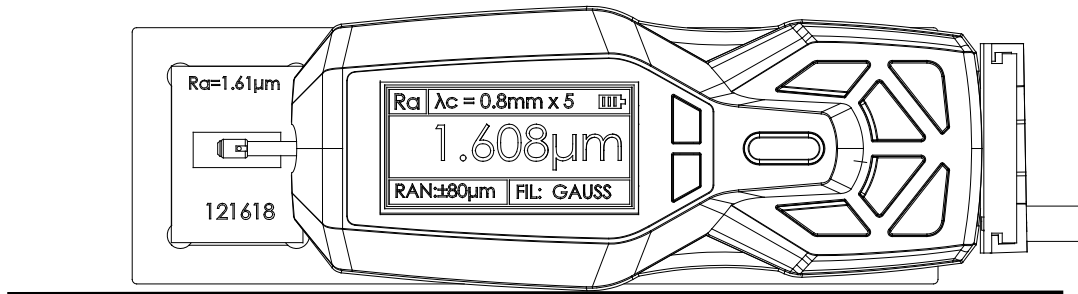

: Correct and standard operation is the premise for accurate measurement

result, please make sure to follow it.

### 2.2 Turning On/Off

Press the key  to hold 2 seconds after the instrument will automatically boot, boot will display equipment type, name and manufacturer information, and then enter the basic measurement status main display interface, as shown.

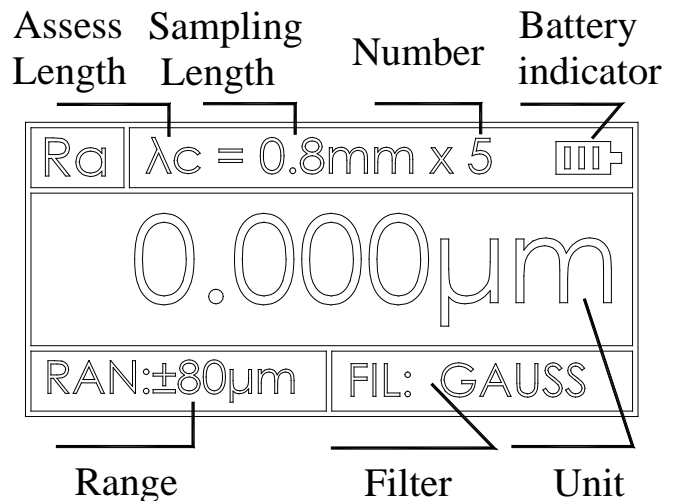

#### Introductions :

1. The next boot will be displayed when the last shutdown set content
2. Startup and shutdown, press and hold the key for about 2 seconds to open the instrument will perform the appropriate action
3. Long time not to use, the instrument should be on the side of the power switch turned off
4. Start measuring sensor is installed, please refer to the stylus position, try to adjust the stylus cursor position to the best position "0"

## 2.3 Stylus Position

First, use the stylus position to determine the location of the sensor. The stylus as measured in the middle position.

In the main interface mode, press the stylus position key  switches stylus position display screen and the main display screen.

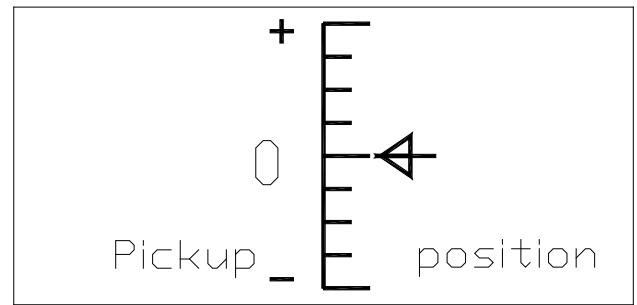

## 2.4 Start measurement

In the main interface mode, press the Start button to start measuring

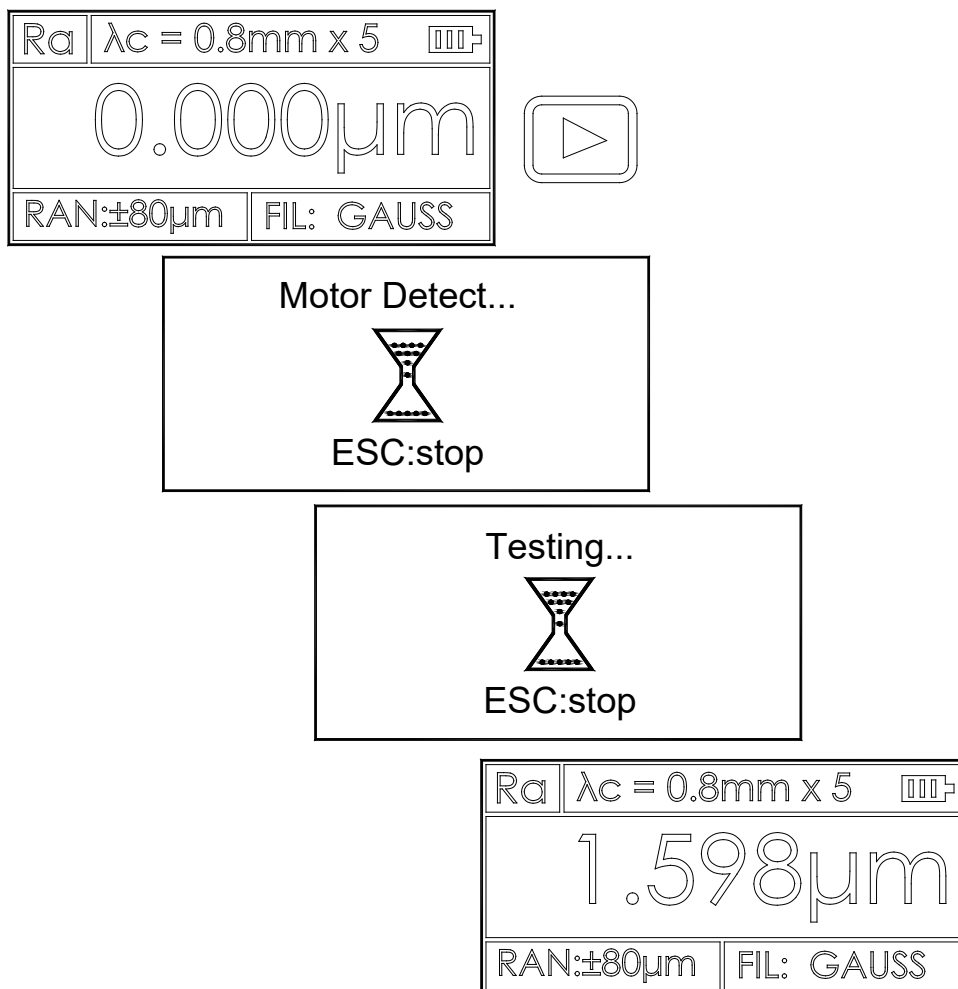

## 2.5 Measurement result display

After the measurement, can be observed in Figure shows the results of all measurements.

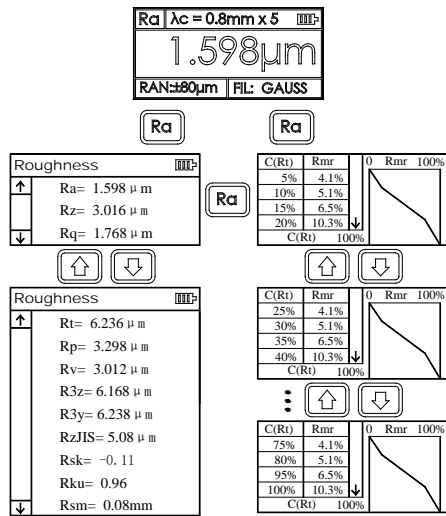

## 2.6 Print measurement results

The instrument can be connected to the printer. The measurement results will be printed.

After measurement, Press **Ra** key to display the measurement results.

Press **Print** key to print the measured data

to a serial printer. At this point, **Print** key is a print key to use.

The instrument can be used according to the actual requirements of arbitrary parameters choose to print or print all the parameters, how to set the parameters, refer to "Print Settings."

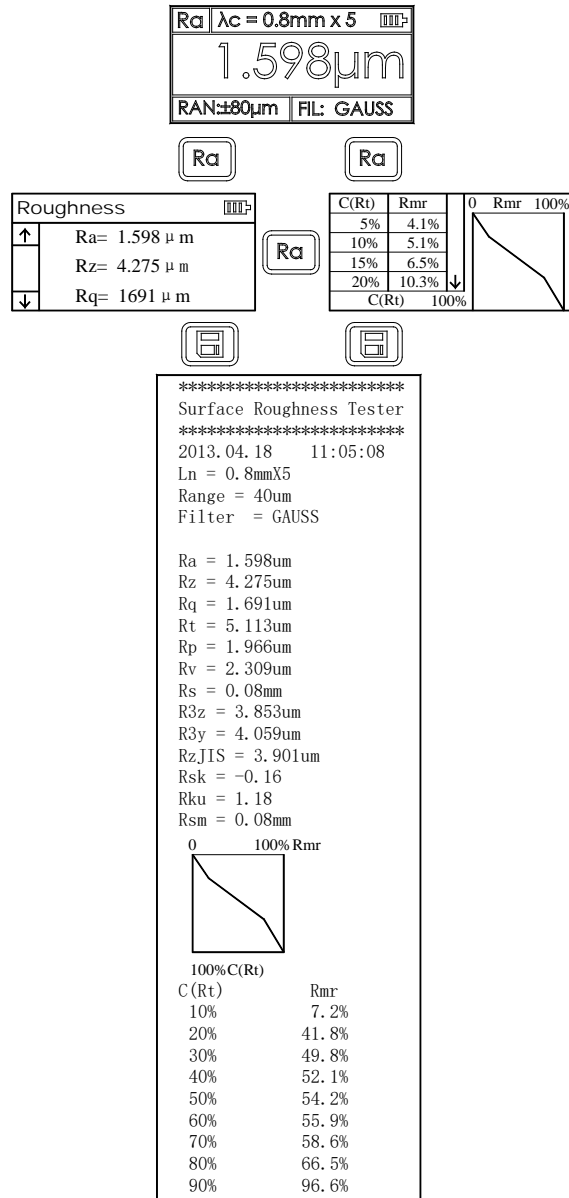



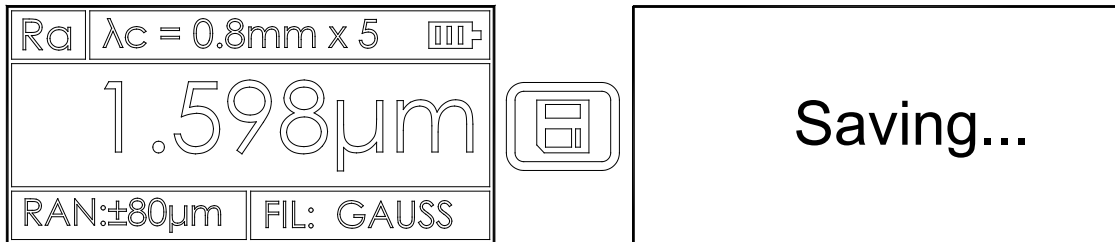

## 2.7 Storage measurement results

In the main display interface mode, press the  key to save the measurement results stored in the instrument memory. Instrument built-in large capacity memory, can store 100 groups of raw data and waveform data.

Data storage recording date and time the file name automatically generated according to the last data record is always stored the most recent recording time, the last data record stored recording record number will be 001.







## 2.8 Measuring parameter Settings

In the basic measurement mode, press the  key to enter the menu operation state, press the   keys to select "Preferences" function, then press the  key to enter the parameter setting mode. In the parameter setting mode, you can modify all the measurement conditions.

Parameter		Content	
↑	▷ λ c	0.8mm	0.25mm; 0.8mm; 2.5mm
	N× λ c	5	1-5
	RANGE	±40 μm	±20; ±40; ±80 μm
	FILTER	GAUSS	RC; PC-RC; GAUSS; D-P
	DISPLAY	Ra	Ra Rz Rt Rq
	UNIT	μ m	μ m μ in
↓	LANGUAGE	ENG	ENG CHS

## 2.9 Storage Management

In the basic measurement mode, press the  key to enter the menu operation state, Press the   keys to select "Recorder" function, Press the  key to enter management projects.

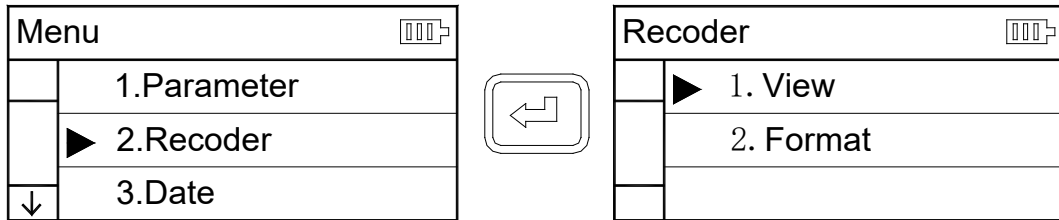

Recorder management by the two project components, 1 view 2 format.  
Selected item and press the Enter key to enter.

### 2.9.1 View Record

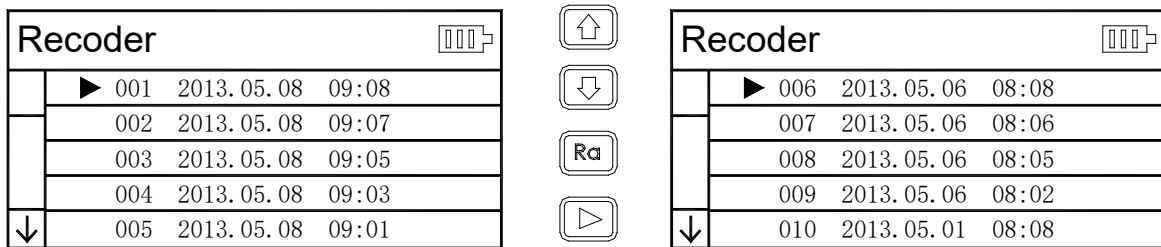

Select the appropriate records, press  View log content

In view records content,  data can be printed according to the specified printer, operate the following figure.

2013.05.06 08:08:16

↑ Ra = 1.598 μm  
Rz = 3.016 μm  
↓ Rq = 1.768 μm

Ra



C(Rt)	Rmr	0 Rmr 100%
5%	4.1%	
10%	5.1%	
15%	6.5%	
20%	10.3%	
C(Rt) 100%		



0.8mmx5 ± 40 μm GAUSS

↑ Rt = 6.236 μm  
Rp = 3.298 μm  
Rv = 3.012 μm  
R3z = 6.168 μm  
R3y = 6.238 μm  
RzJIS = 5.08 μm  
Rsk = -0.11  
Rku = 0.96  
↓ Rsm = 0.08mm

C(Rt)	Rmr	0 Rmr 100%
25%	4.1%	
30%	5.1%	
35%	6.5%	
40%	10.3%	
C(Rt) 100%		



C(Rt)	Rmr	0 Rmr 100%
75%	4.1%	
80%	5.1%	
95%	6.5%	
100%	10.3%	
C(Rt) 100%		



Print



```

*****
Surface Roughness Tester
*****
2013.04.18 11:05:08
Ln = 0.8mmX5
Range = 40um
Filter = GAUSS

Ra = 1.598um
Rz = 4.275um
Rq = 1.691um
Rt = 5.113um
Rp = 1.966um
Rv = 2.309um
Rs = 0.08mm
R3z = 3.853um
R3y = 4.059um
RzJIS = 3.901um
Rsk = -0.16
Rku = 1.18
Rsm = 0.08mm

0 100% Rmr

100% C(Rt)
C(Rt) Rmr
10% 7.2%
20% 41.8%
30% 49.8%
40% 52.1%
50% 54.2%
60% 55.9%
70% 58.6%
80% 66.5%
90% 96.6%

```



## 2.9.2 Format

Data format is the deletion of data records, once formatted and all data will be cleared. In the data before formatting instrument has confirmation prompt information, user data will not be restored after confirmation.

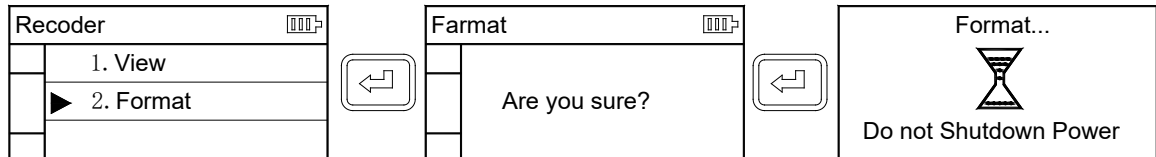

## 2.10 Date Settings

Built-in real time clock calendar instrument used to record information about the test of time to adjust date and time as follows

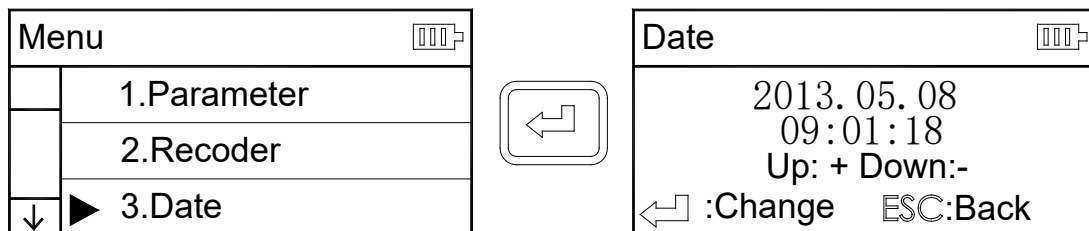

## 2.11 Software Information

Instruments software and hardware information can help users easily upgrade and maintain the product, unique serial number of the instrument software information items are displayed.

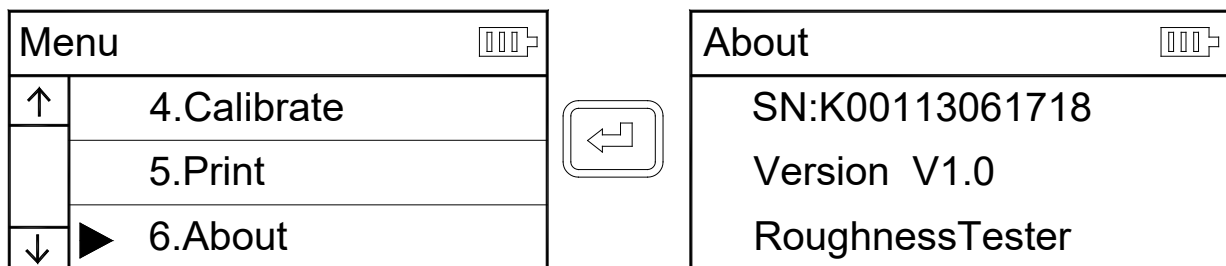



## 2.12 Parameter calibration

Before measuring instrument, usually required calibration use standard calibration Block. The instrument is configured with a standard calibration block, before measurement, instruments to test the block. Under normal circumstances, when the measured value and the block value of the difference in the acceptable range, the measurement value is valid, can be measured directly.

If the measured value and the block value of the difference is greater than a accuracy error range of the instrument, or the user require high accuracy, can be used to correct the indication calibration function and improve measurement accuracy. Showing the value of the calibration procedure as shown.

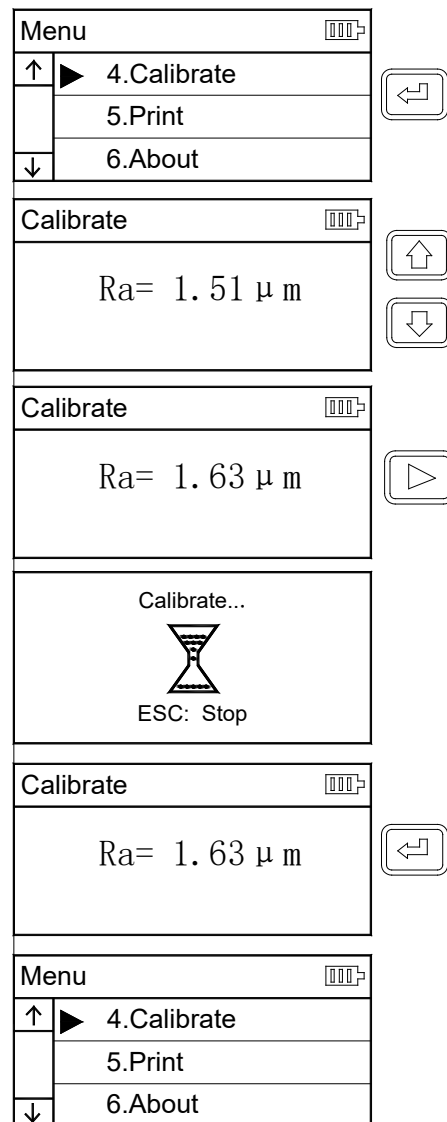
Illustration is based on a model calibrated 1.63 $\mu\text{m}$  steps to calibrate the model for the actual calibration of the nominal value of the set value.



- 1、 Under normal circumstances, the instrument in the factory have been rigorously tested, showing error is much less than  $\pm 10\%$ , in this case, the user is not showing the value of the calibration frequently used functions.
- 2、 After setting the calibration value, you must press the  key for a full measurement, instrument calibration to be valid.
- 3、 New parameters after calibration must be carried out once a complete measurement and press the  key is stored in the instrument.
- 4、 Press "ESC" key to return the menu without saving calibration results.

## 2.13 Print setup

The instrument can be used according to the actual requirements of any parameter selection Print or Print All, the steps shown in Figure.

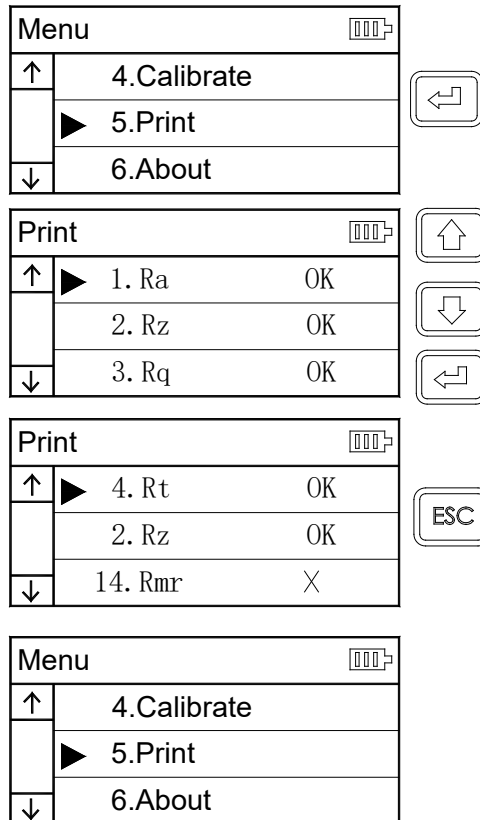

### 3 Options and Usage

#### 3.1 Adjustable support

When measured surface of part is smaller than the bottom surface of the instrument, sheath of pickup and adjustable supporter of instrument options can be used for auxiliary support to complete the measurement (as shown in Figure).

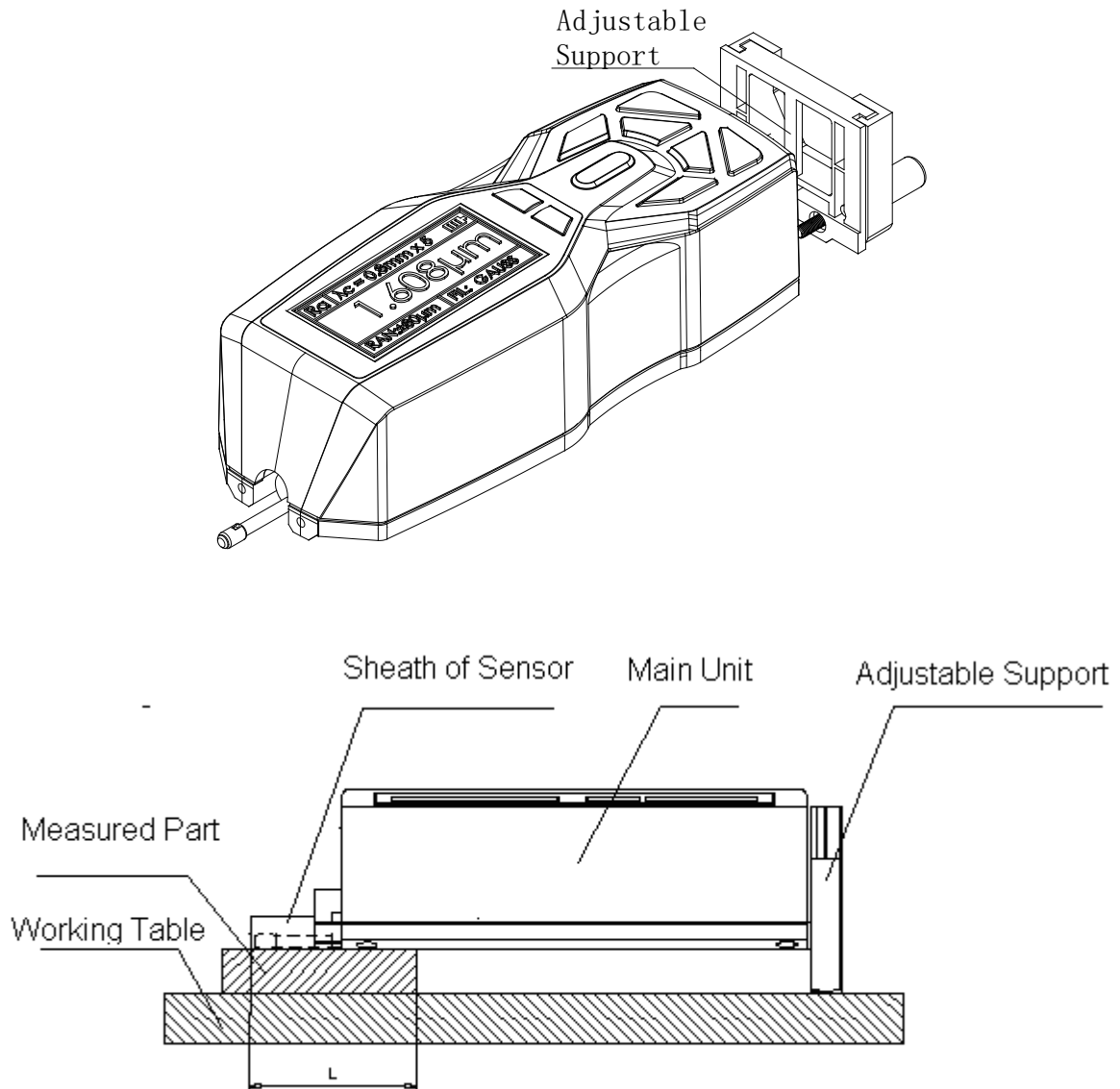

- 1.the value L above shall not be shorter than driving stroke of this measurement to prevent pickup from dropping out of part during measurement.
2. Locking of adjustable supporter shall be reliable

### 3.2 Measurement Stand

Measurement Stand can adjust the positions between tester and measured part conveniently with flexible and stable operation and wider application range. Roughness of complex shapes can also be measured. Measurement stand enable the adjustment of the position of stylus to be more precise and measurement to be more stable. If Ra value of measured surface is relatively low, Using measurement platform is recommended.

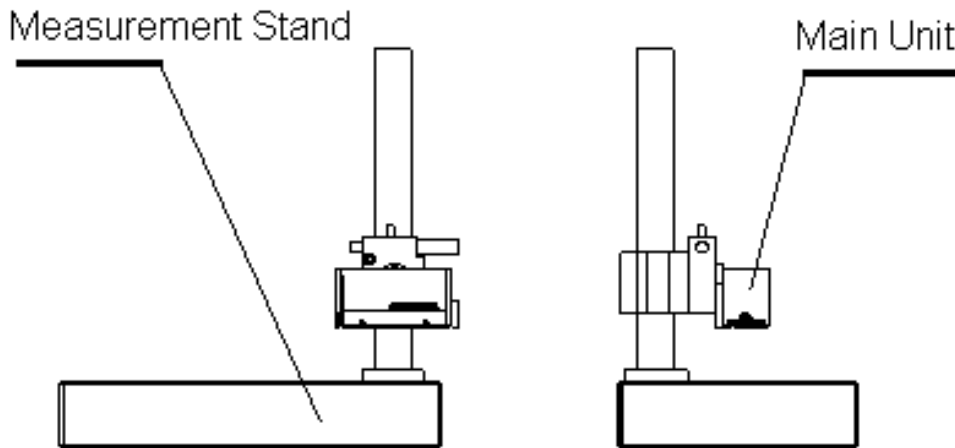

### 3.3 Extending Rod

Extending rod increases the depth for pickup to enter the part. Length of extending rod is 50mm.

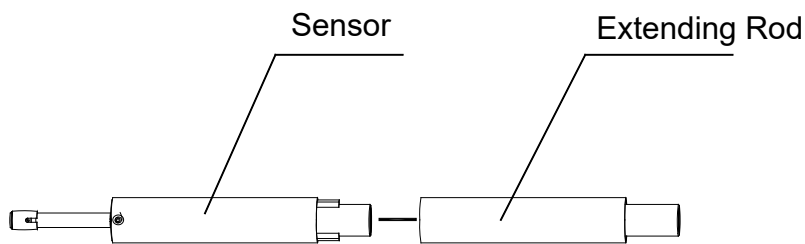

### 3.4 Standard Sensor

The standard sensor can measure most types of the plane like inclined plane, cone surface, inner hole, groove and other surface roughness. The device can be used for hand-held measurement only in addition to the standard sensor. Other special sensors are needed to measure the measuring platform.

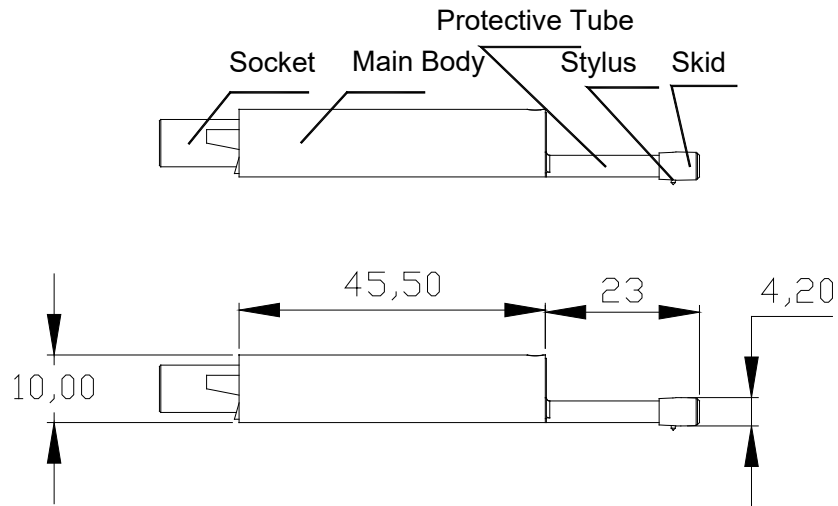

### 3.5 Curved Surface Sensor

Curved surface sensor is mainly used for measuring radius is larger than the smooth cylindrical 3mm surface roughness, for the larger radius smooth spherical surface and other surface also can obtain good approximation, the radius of curvature, the surface is smooth, the better the effect of measurement.

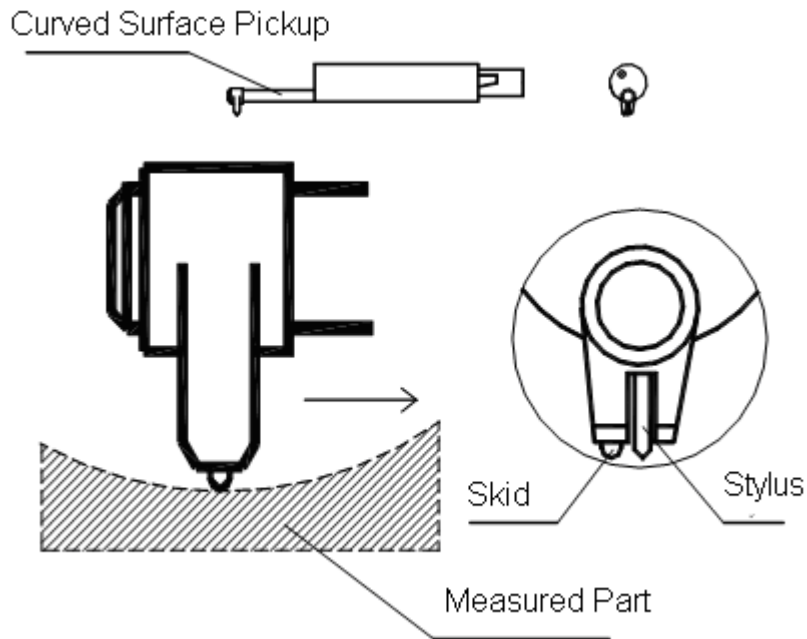

### 3.6 Pinhole sensor

Using Pinhole pickup, the inner surfaces of holes with radius more than 2mm can be measured. Refer to the following Figure for detailed dimension.

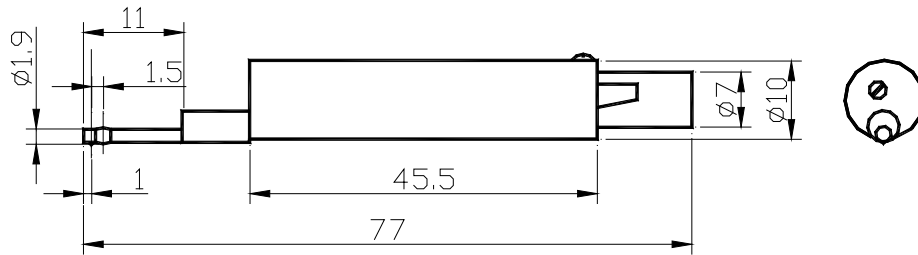

Pinhole pickup

### 3.7 Deep Groove Sensor

With deep groove sensor, it is possible to measure groove with width wider than 3mm and depth deeper than 10mm, or the surface roughness of step with height less than 10mm, Also can used to measure the planar, cylindrical used with platform. please see figure for detailed dimension.

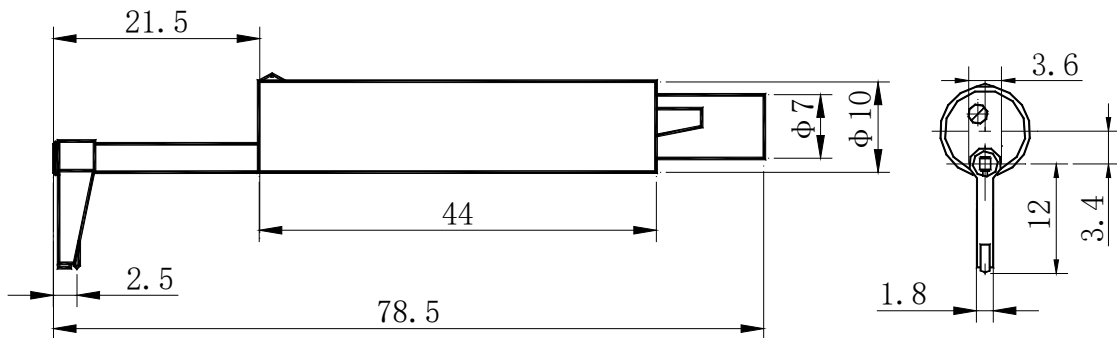

deep groove sensor

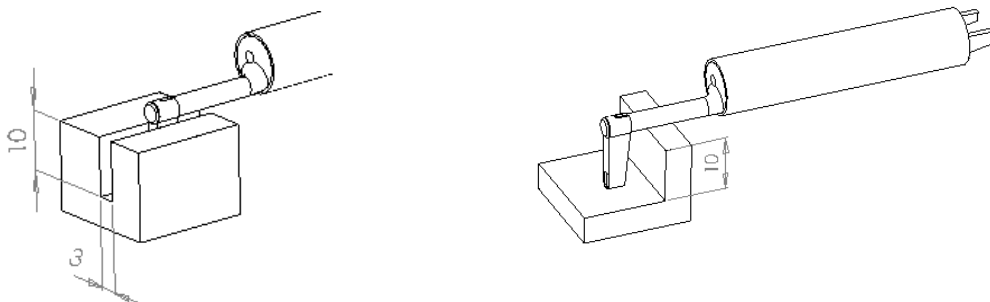

## 4 Technical Parameter and Features

### 4.1 Technical Parameter

Name		Content
Measurement Range	The Z axis (vertical)	160 $\mu$ m
	The X axis (horizontal)	17.5mm
Resolution ratio	The Z axis (vertical)	0.01 $\mu$ m/ $\pm$ 20 $\mu$ m
		0.02 $\mu$ m/ $\pm$ 40 $\mu$ m
		0.04 $\mu$ m/ $\pm$ 80 $\mu$ m
Measurement item	Parameter	Ra Rz==Ry(JIS) Rq Rt==Rmax
		Rp Rv R3z R3y Rz(JIS)
		Rs Rsk Rku Rsm Rmr
	Standard	ISO, ANSI, DIN, JIS
	Graphic	Material ratio curve
Filter		RC, PC-RC, Gauss, D-P
The sampling length( <i>lr</i> )		0.25,0.8,2.5mm
Assessment length ( <i>ln</i> )		$Ln = lr \times n$ n=1~5
Sensor	Principle	The displacement differential inductance
	Stylus	Natural Diamond, 90° cone angle, 5 $\mu$ m tip radius
	Force	<4mN
	Skid	Ruby, Longitudinal radius 40mm
	Traversing speed	<i>lr</i> =0.25, <i>Vt</i> =0.135mm/s
		<i>lr</i> =0.8, <i>Vt</i> =0.5mm/s
		<i>lr</i> =2.5, <i>Vt</i> =1mm/s
Return <i>Vt</i> =1mm/s		
Accuracy		No more than $\pm$ 10%
Repeatability		No more than 6%
Power supply		Built-in 3.7VLithium ion battery, Charger :DC5V,800mA/3hour
Working Time		More than 20 hours
Outline dimension L×W×H		141×55×40mm
Weight		About 400g
working Environment		Temperature: -20°C ~ 40°C Humidity: < 90% RH
Store and Transportation		Temperature: -40°C ~ 60°C Humidity: < 90% RH



## 4.2 Measuring Range

Parameter	Measuring range
<b>Ra</b> <b>Rq</b>	0.005 $\mu$ m ~ 16 $\mu$ m
<b>Rz</b> <b>R3z</b> <b>Ry</b> <b>Rt</b> <b>Rp</b> <b>Rm</b>	0.02 $\mu$ m ~ 160 $\mu$ m
<b>Sk</b>	0 ~ 100%
<b>S</b> <b>Sm</b>	1mm
<b>tp</b>	0 ~ 100%

## 5 General Maintenance

### 5.1 Sensor

1. Any time swap sensors are to be especially careful, careful not to touch the guide head and a stylus, because this is a key part of the whole instrument, to try to hold the sensor guide head bracket roots (the front of the body) plug.
2. To complete the measurement work, please timely sensor into the box;
3. Please pay attention to protect the needle part measuring sensor.
4. The sensor's precision components, any knock, touch, fall off phenomenon may damage the sensor, should try to avoid such situations.
5. The sensor is a damageable part and do not belong to the scope of warranty parts. on. In order not to affect the measurement work, users are advised to buy a second sensor used for emergency.

### 5.2 Main Unit

1. Pay attention to maintaining the Main Unit surface clean, often with a soft dry cloth to clean its surface.
2. The instrument is a precision measuring instrument, should always be handled with care, to avoid the shock.

### 5.3 Battery

1. Always observe the battery prompt, when the low voltage, please charge.
2. The charging time is 3 hours, try not to long time charge.

## 5.4 Standard Sample Plate

1. The surface of a standard sample plate must be kept clean.
2. To avoid scratches on the surface of sample area.

## 5.5 Troubleshooting

When the tester breaks down, handle the troubles according to measures described on Fault Information. If troubles still exist, please return the instrument to factory for repair. Users should not dismantle and repair the device by themselves. Returned instrument should be accompanied with sample plate attached. Phenomenon of problem should be explained.

<b>Error message</b>	<b>Cause</b>	<b>Solutions method</b>
Motor error	Motor stuck	Reboot
Out of Range	<ol style="list-style-type: none"><li>1. The measured surface signal exceeding the measurement range</li><li>2. Placed away from the center of the stylus position</li></ol>	<p>Increase Measuring range</p> <p>Adjust the Stylus position</p>
No test data	After the boot does not measure.	The actual measurement: one time
Measurement Accuracy Out of Range	Set the parameter error Calibration data error	Set the parameter measurement Calibrate the tester

## 6 References

### 6.1 Terms

The instrument calculate parameters on the filter profile and the direct profile, all calculated in line with the GB / T 3505-2000 "Geometrical Product Specification(GPS) —— Surface texture:

Profile method — Term, definitions and surface texture parameters."

### 6.1.1 Terms

**Filtered profile:** profile signal after primary profile is filtered to remove waviness.

**D-P (direct-profile):** adopt central line of Least Square Algorithm.

**RC filter:** analogue 2RC filter with phase difference.

**PC-RC filter:** RC filter with phase-correction.

**Gauss filter:** ISO11562.

### 6.1.2 Traversing Length

● RC Filter

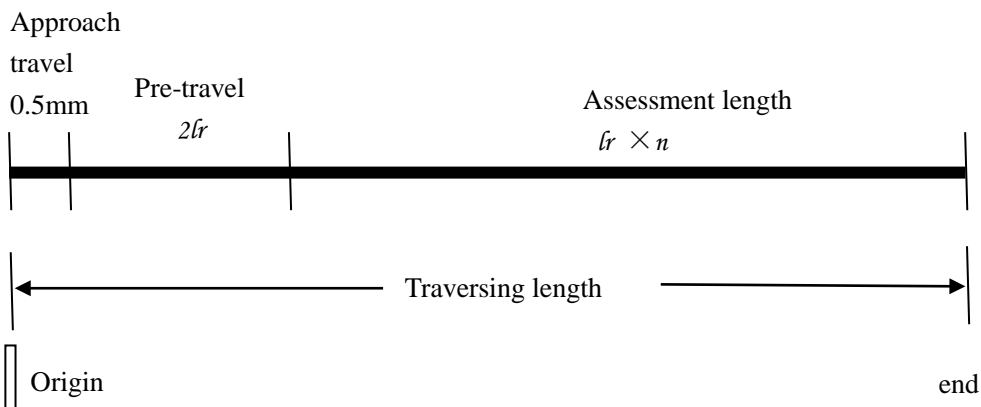

● GAUSS Filter

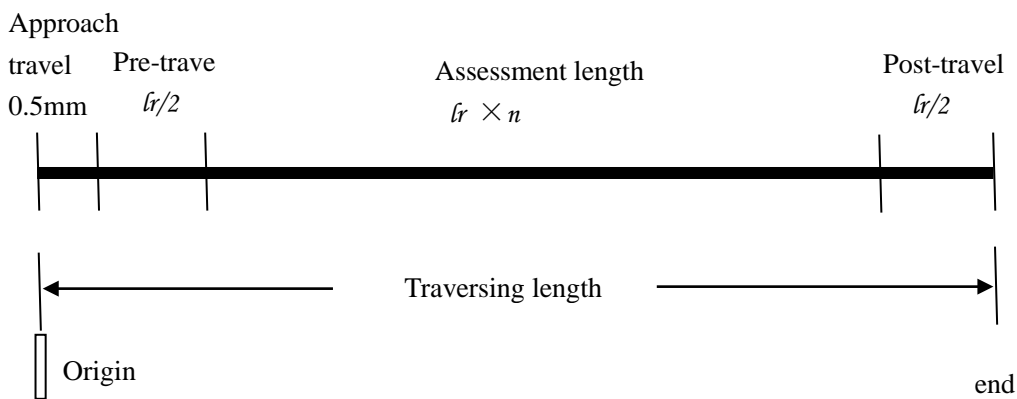

● PCRC Filter

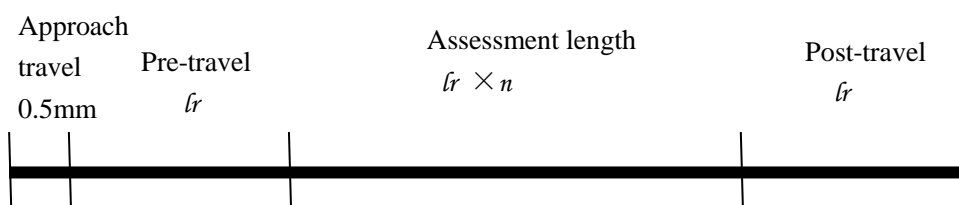

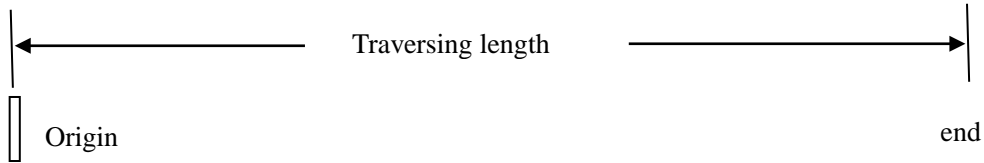

## 6.2 Parameters Definitions

### 6.2.1 Arithmetical Mean Deviation of Profile **Ra**

Ra is arithmetic mean of the absolute values of profile deviation  $Z(x)$  from mean within sampling length.

$$Ra = \frac{1}{l} \int_0^l |Z(x)| dx$$

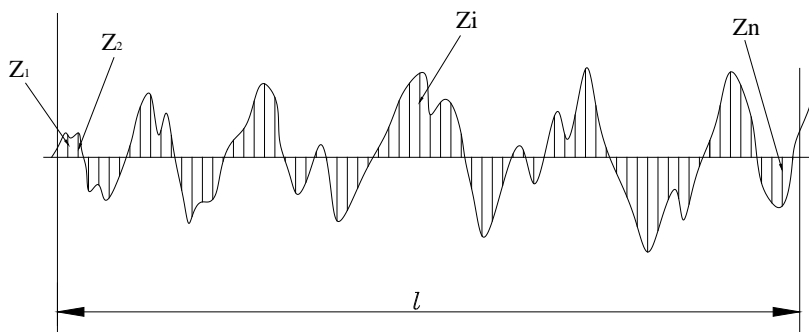

### 6.2.2 Root-mean-square Deviation of Profile **Rq**

Rq is the square root of the arithmetic mean of the squares of profile deviation  $Z(x)$  from mean within sampling length.

$$Rq = \sqrt{\frac{1}{l} \int_0^l Z^2(x) dx}$$

### 6.2.3 Maximum Height of Profile **Rz**

Rz is the sum of height  $Zp$  of the highest profile peak from the mean line and depth  $Zv$  of the deepest profile valley from the mean line within sampling length.

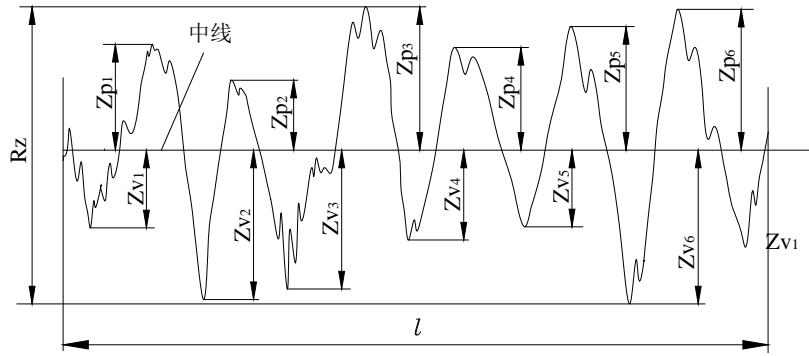

### 6.2.4 Total Peak-to-valley Height $R_t$

$R_t$  is the sum of the height of the highest peak  $Z_p$  and the depth of the deepest valley  $Z_v$  over the evaluation length.

### 6.3 Recommended table of the sampling length

Ra ( $\mu\text{m}$ )	Rz ( $\mu\text{m}$ )	Sample length
>5~10	>20~40	2.5
>2.5~5	>10~20	
>1.25~2.5	>6.3~10	0.8
>0.63~1.25	>3.2~6.3	
>0.32~0.63	>1.6~3.2	
>0.25~0.32	>1.25~1.6	0.25
>0.20~0.25	>1.0~1.25	
>0.16~0.20	>0.8~1.0	
>0.125~0.16	>0.63~0.8	
>0.1~0.125	>0.5~0.63	
>0.08~0.1	>0.4~0.5	
>0.063~0.08	>0.32~0.4	
>0.05~0.063	>0.25~0.32	
>0.04~0.05	>0.2~0.25	
>0.032~0.04	>0.16~0.2	
>0.025~0.032	>0.125~0.16	
>0.02~0.025	>0.1~0.125	





**SaluTron Messtechnik GmbH**

Dr.-Gottfried-Cremer-Allee 30/7 · D-50226 Frechen  
Tel. +49 (0) 2234 99 99 96 0 · Fax. +49 (0) 2234 99 99 96 2  
E-Mail: [info@salutron.de](mailto:info@salutron.de) · [www.salutron.de](http://www.salutron.de)